

MASTER[®]

PORTABLE GASOLINE GENERATORS

OWNER'S OPERATION AND INSTALLATION MANUAL



Generator Models: HWI3000A, MGH3000GA, MGH3000A, MGH4000D, MGH4000DI, MGH5000E, MGH5000EI, MGH5000EIE, and MGH6500AIE

IMPORTANT: Read and understand this manual before operating or servicing generator. Improper use of generator can cause serious injury. Keep this manual for future reference.

MASTER[®]

PORTABLE GASOLINE GENERATORS

SAFETY INFORMATION

WARNINGS

IMPORTANT: Read this owner's manual and the engine owner's manual carefully. Become familiar with this generator before trying to operate or service it. Know its uses, limitations, and any hazards involved. Improper use of generator can cause severe injury or death from explosion, fire, burns, electrical shock, or carbon monoxide poisoning.

 DANGER: Carbon monoxide poisoning may lead to death!

Engine exhaust contains poisonous carbon monoxide gas. Overexposure will cause loss of consciousness and will lead to death. Use only in well-vented areas. Make sure area has plenty of free-moving, fresh, outside air. Never run generator in an enclosed or confined area. Never run generator inside occupied building.

Carbon Monoxide Poisoning: Early signs of carbon monoxide poisoning resemble the flu, with headaches, dizziness, and nausea. If you have these signs, get fresh air at once! Some people are more affected by carbon monoxide than others. These include pregnant women, persons with heart or lung disease or anemia, those under the influence of alcohol, and those at high altitudes. Make certain you read and understand all warnings. Keep this manual for reference. It is your guide to safe and proper operation of this generator.

Safety information appears throughout these instructions. Pay close attention to them. Below are definitions for the safety information listed throughout this manual.

DANGER: indicates a hazard which will cause severe personal injury, death, or substantial property damage if you ignore warning.

WARNING: indicates a hazard which can cause severe personal injury, death, or substantial property damage if you ignore warning.

CAUTION: indicates a hazard which will or can cause minor personal injury or property damage if you ignore warning.

1. Gasoline presents a hazard of fire or explosion. Gasoline is flammable. Its vapor is explosive.
 - Keep fuel out of children's reach.
 - Refuel generator in a well-vented area. Do not fill fuel tank in the dark. Do not refuel while engine is running. Unhook all electrical loads and shut off engine before refueling.
 - Do not overfill fuel tank. Always allow room for fuel to expand. If you overfill tank, fuel can overflow onto hot generator. This can cause fire or explosion. After refueling, tightly close fuel tank cap.
 - Do not spill fuel. Fuel or fuel vapor may ignite. If fuel spills, make sure area is dry before starting engine.
 - Never smoke in refueling area. Never allow open flames or sparks in area.
 - Store fuel in approved container. Store fuel in a well-vented area free of open flames or sparks.
2. Guard against fire hazard. Keep operation area well-vented. Keep generator at least three feet away from any object. Do not place flammable objects near generator.
 - Do not use generator where flammable vapors are present. Some vapors are heavier than air. These vapors settle in low-lying places.
 - Do not use generator in enclosed spaces. This includes motor home or RV generator compartments.
3. Guard against electric shock. Generator produces high voltage. This high voltage can cause severe electric shock. Only responsible adults should use generator.
 - Properly ground generator before starting.
 - Never let anyone operate or service generator without proper instructions.
 - Avoid contact with live terminals or bare wires.
 - Do not use generator outdoors in rain or snow.
 - Do not use generator near standing water or snow.
 - Do not use if generator is wet or damp.
4. Guard against burns. Hot engine parts can cause severe injury. Use caution and remain alert when using generator.
 - Keep children and animals away from generator while it is running or hot.
 - Keep all covers and shields in place. Keep them tightly secured.
 - The muffler becomes very hot during operation. The muffler remains hot for a while after shutdown. Do not touch muffler while it is hot. Do not let muffler touch anything flammable. Let engine cool before transporting or storing.
5. Have standby installation to home or building performed by a licensed electrician. Do not let anyone else wire into a utility circuit. Personal injury, equipment damage, or damage to home could occur.
6. Never connect generator to any existing electrical circuits. The generator output will back-feed into the utility power line. This may electrocute a power company line repair person. Also, if generator is powering electrical circuits, the chance of an electrical fire exists.
7. Battery gives off explosive gases. Keep sparks, flames, and cigarettes away. Do not remove or install battery cables when engine is cranking or running. Only service or use battery in a well-vented area.
8. Battery contains sulfuric acid. Battery acid is poisonous if swallowed. Contact with skin or eyes may cause severe burns. Do not tilt generator with battery installed. Tilting could cause battery acid to spill. Wear protective clothing and face shield when servicing. Keep out of children's reach.

SAFETY INFORMATION

Continued

9. Only a qualified electrical service person should service and repair generator.
 - Generator produces high voltage. Use extreme caution when working on electrical parts.
 - Always remove spark plug wire from spark plug before servicing. This will prevent accidental starting.
 - When working on generator, avoid hot muffler, exhaust manifold, and engine parts. Severe burns may occur.
 - Do not work on generator when tired.
 - Use only factory approved replacement parts.
10. Store generator in a well-vented area. Make sure fuel tank is empty. Never store with fuel in tank. Vapors may reach an open flame or spark. Fire or explosion may result.
11. Never operate generator
 - if engine speed changes greatly
 - if engine misfires often
 - if powered items overheat
 - if electrical output drops
 - if it is sparking
 - if it produces smoke or flames
 - if it vibrates at high levels
 - if it has a damaged receptacle
12. Keep generator and nearby areas clean.
 - Keep generator free of oil, mud, and other foreign matter.
 - Remove anything that creates slippery areas around generator.
 - Remove oily rags and other items that create fire hazards.
 - Keep a fire extinguisher nearby. Make sure it is rated ABC by the NFPA. They are good for all uses. Consult your local fire department.
 - Keep fire extinguisher well maintained. Be familiar with its use.
13. Know how to stop engine quickly. Know how to use all controls.
14. Prolonged exposure to loud noise can cause hearing loss.
 - When working around generator, wear approved hearing protection.
 - Remember neighbors when using generator.

PRODUCT IDENTIFICATION

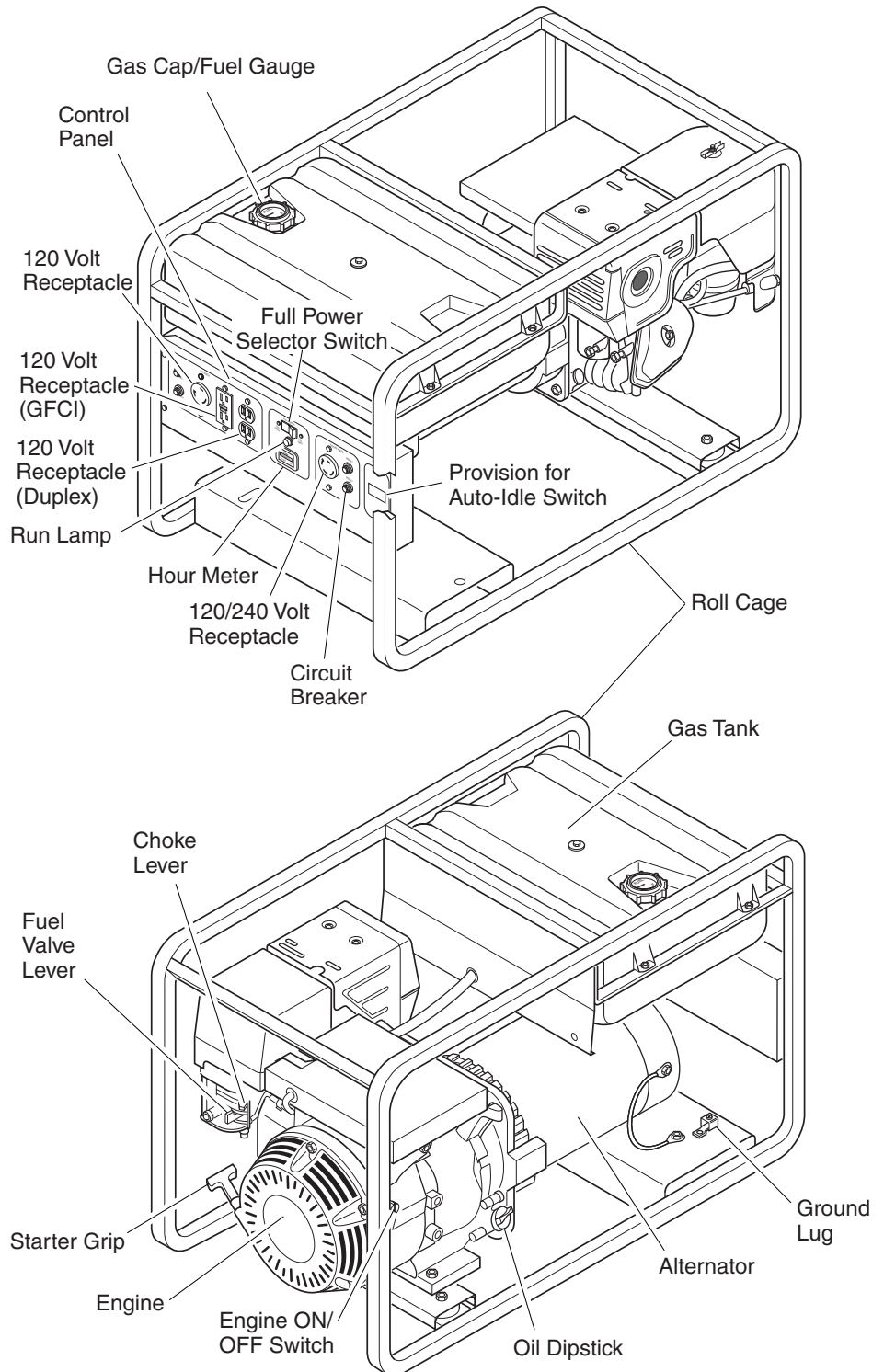

Figure 1 - Portable Generator (Model MGH4000D Shown)

MASTER[®]

PORTABLE GASOLINE GENERATORS

GENERAL INFORMATION

Master portable generators are rugged and compact. These generators use brushless alternators for dependable, trouble-free service. Honda gasoline engines provide long life under heavy use. Honda engines have overhead valves (OHV). This provides high performance with lower fuel consumption. These engines are governed to maintain engine speed of 3600 RPM under load. 3600 RPM engine speed provides 120/240V, 60 Hz power.

Additional Features

- Circuit breaker protection
- Spark-arresting muffler
- Large fuel tank
- Oil alert system
- Electric starter (models MGH5000EIE and MGH6500AIE)
- 15-Amp ground fault circuit interrupter (GFCI) receptacle (Except HWI3000A Model)

UNPACKING

1. Remove generator from carton.
2. Remove any protective packaging applied to generator for shipment.
3. Check for loose or missing parts. Check for shipping damage. If any parts are missing or damaged, promptly inform dealer where you bought generator.
4. Battery cables are supplied for models MGH5000EIE and MGH6500AIE only. These cables are in a separate bag inside generator carton. You must install these cables to engine. See *Battery*, page 8 for installation instructions.

VENTILATION

⚠ DANGER: Use only in well-ventilated areas. Make sure area has plenty of free-moving, fresh, outside air. Never run generator in an enclosed or confined area. Never run generator inside occupied building. Engine exhaust contains poisonous carbon monoxide gas. Overexposure will cause loss of consciousness and will lead to death.

This generator needs cooling air to run properly. Never block free-flowing, cooling air to generator. Overheating will occur without cooling air. This will damage the generator. Keep generator at least three feet away from any object.

DUST, DIRT, RAIN, AND SNOW

⚠ WARNING: Do not use generator outdoors in rain or snow. Do not use generator near standing water or snow. Do not use if generator is wet or damp. Operating generator in these conditions increases the risk of electrocution. Severe injury or death can occur.

Do not use generator in extremely dusty or dirty conditions. This will severely affect its life. Keep generator clean. Do not allow dust, dirt, rain, or snow to collect on it. Protect generator from outdoor elements.

HIGH AND LOW TEMPERATURE OPERATION

Air temperature affects generator output. Output drops 1% for each 10° temperature rise above 60° F. Very low temperatures may make the engine hard to start. See engine owner's manual for more information.

OWNER'S MANUAL

SPECIFICATIONS

MODEL	HWI3000A	MGH3000GA	MGH3000A	MGH4000D	MGH5000E	MGH6500AIE
				MGH4000DI	MGH5000EI	
Electrical						
Rated Wattage	2500	2500	2500	4000	5000	6500
Rated Amperage						
120 V	20.8	20.8	20.8	33.3	41.7	57
240 V	—	—	—	16.7	20.8	28.3
Receptacle						
120-V Duplex	—	—	—	Yes	Yes	Yes
120-V, 20-A Duplex	Yes	—	—	—	—	—
120-V, 15-A GFCI	No	Yes	Yes	Yes	Yes	Yes
120-V Twist-Lock	No	No	No	30 Amp	30 Amp	30 Amp
120/240-V Twist-Lock	No	No	No	20 Amp	20 Amp	30 Amp
120-V Full-Power Switch	No	No	No	Yes	Yes	No
120/240-V, 50-A	No	No	No	No	No	No
General						
Honda Engine H.P.	5.5	5.5	5.5	8	9	13
Honda Model	GX160K1VX	GX160K1VX	GX160K1VX	GX240K1VA	GX270VA	GX390K1VXE
Fuel Type	Gasoline	Gasoline	Gasoline	Gasoline	Gasoline	Gasoline
Fuel Tank Capacity	3.9 qt.	3.9 qt.	3.9 qt.	5 gal.	8 gal.	8 gal.
Oil Alert System	Yes	Yes	Yes	Yes	Yes	Yes
Start Method	Recoil	Recoil	Recoil	Recoil	Recoil/Elec.	Electric
Weight (pounds)	85.5	85.5	85.5	139	173	247

* Single-phase, 1.0 power factor

Note: Ratings apply to SAE standard conditions. Reduce ratings 3 1/2% for each 1000 feet above sea level and 1% for each 10° Fahrenheit rise above 60°F.

MASTER[®]

PORTABLE GASOLINE GENERATORS

GENERATOR FEATURES

OIL ALERT SYSTEM

The oil alert system protects the engine from low oil damage. This system automatically shuts down the engine and prevents engine restarting if the oil level falls too low.

Note: When this happens, the engine switch remains in the ON position. The oil alert system is wired into the ON/OFF Switch.

If this system shuts down the engine, the engine will not start until you add oil. Add oil to engine (see *Engine Oil*, page 7).

Note: Operate generator on a level surface. If not level, the oil may flow away from the oil level sensing device. This will cause the oil alert system to shut down engine.

See engine owner's manual for more information.

Models HWI3000A, MGH3000GA, MGH3000A, MGH4000D, MGH4000DI, MGH5000E, and MGH5000EI



Models MGH5000EIE and MGH6500AIE

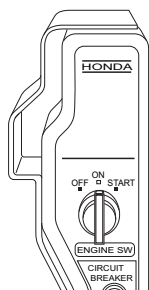

Figure 2 - Engine Switch Location

FULL POWER SELECTOR SWITCH

All models except HWI3000A, MGH3000GA, MGH3000A and MGH6500AIE have a full power selector switch on the control panel. The switch has two positions: 120 VOLT ONLY, and 120/240 VOLT.

120 VOLT ONLY: This position sends full power to the 120V receptacles only. 240V power is not available. Use this position when powering 120V items only.

120/240 VOLT: This position sends full power to the 120/240V receptacle. It also powers the 120V receptacles at reduced wattage capacity.

IMPORTANT: Do not move the full power selector switch while powering electrical items. Unplug all items before moving switch. Failure to do so can damage switch. Models HWI3000A, MGH3000GA, MGH3000A, and MGH6500AIE do not have this switch. These models provide full power to all receptacles.



Figure 3 - Full Power Selector Switch

AUTO-IDLE SYSTEM

The Auto-Idle System allows the engine to idle down or run at a slower speed when the generator is not being used to supply power. The Auto-idle system can be turned ON or OFF by a rocker switch on the control panel. When the switch is in the OFF position, the engine runs at full speed all of the time. When the switch is in the ON position, the engine slows down to idle speed until an electrical load is applied. When a load is applied to the generator (an electrical item is plugged in and turned on) the engine speeds up to the preset speed required to produce the correct voltage.

IMPORTANT: A minimum current load of 1 Amp is required to disengage the auto idle solenoid and cause the engine to come up to speed for correct voltage. Powering items at reduced engine speed will damage generator and powered items.

ELECTRIC START (Models MGH5000EIE and MGH6500AIE)

Models MGH5000EIE and MGH6500AIE have electric starters. A battery is not supplied with generator. You must provide a 12-volt, 32-amp-hour battery. For more battery information, see *Battery*, page 8.

GROUND FAULT CIRCUIT INTERRUPTER RECEPTACLE

All models (Except HWI3000A) have a 120-volt ground fault circuit interrupter (GFCI) receptacle. The GFCI receptacle is on the control panel or top cover of alternator (models MGH3000GA and MGH3000A only). The GFCI protects you against hazardous electrical shock caused when your body becomes a path through which electricity travels to reach ground. This could happen when you touch an appliance or cord that is 'live' through faulty mechanism, damp or worn insulation, etc.

When protected by the GFCI, you may still feel a shock, but the GFCI should cut it off quickly. A person in normal health should not receive serious injury. **Note:** Infants and very small children may still be affected.

Test Procedure

Check the GFCI receptacle every month. This insures it is working right.

1. Push black TEST button. Red RESET button should pop out. This should trip GFCI, resulting in no electrical power at receptacle. Verify this by plugging test lamp with good bulb into receptacle. If lamp does not work, GFCI receptacle is good.

⚠ WARNING: If RESET button does not pop out, do not use the GFCI receptacle. Contact a qualified electrician for repairs.

GENERATOR FEATURES

Continued

- If the GFCI receptacle tests okay, restore power by pushing the RESET button back in. The test lamp should work at this time. **IMPORTANT:** You must press the RESET button firmly and fully. It should lock into place. If the GFCI does not lock into place, do not use receptacle. Contact a qualified electrician for repairs.

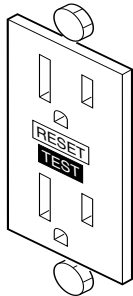

Figure 4 - GFCI Receptacle

ENGINE CIRCUIT BREAKER (Models MGH5000EIE and MGH6500AIE)

This circuit breaker, or fuse, protects the battery charging circuit. A short circuit will trip the circuit breaker. The circuit breaker will also trip if you install battery wrong. Push circuit breaker button to reset.

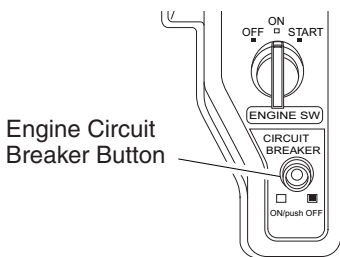

Figure 5 - Engine Circuit Breaker

RECEPTACLE CIRCUIT BREAKER

The circuit breakers protect the receptacles and alternator. Overloading generator will trip circuit breaker. A short circuit in item being powered will also trip breaker. If this occurs, unplug electrical load from receptacle. Let circuit breaker cool down. Push circuit breaker button to reset.

Electric motors need higher starting current. They require up to three-times their rated wattage to start. The starting current needed may be too high. This can cause nuisance circuit breaker tripping. To help prevent this, start electric motors first. Connect additional items to generator after starting motors. If this continues to happen, reduce the total generator load.



Figure 6 - Receptacle Circuit Breaker Button

Note: High ambient temperature will cause nuisance tripping.

ENGINE OIL

We ship the generator without oil in the engine crankcase. You must add oil before starting engine. See engine owner's manual for specific oil type.

CHECKING OIL LEVEL AND ADDING OIL

Follow steps below to check oil level. Make sure engine is level and stopped.

- Remove dipstick (see Figure 7). Wipe dipstick clean.
- Insert dipstick into oil filler neck. Do not screw it in. Oil level should be at top of filler neck. Oil should cover most of dipstick.
- If level is low, fill to top of oil filler neck (see Figure 7). Only use oil recommended in engine owner's manual.

Note: If oil level is too low, oil alert system will shutdown engine and prevent engine from restarting.

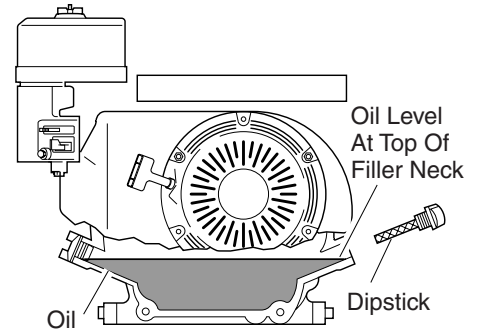

Figure 7 - Checking Oil Level (Model MGH4000D Shown)

FUEL

WARNING: Gasoline presents a hazard of fire or explosion. Gasoline is flammable. Its vapor is explosive.

- Keep fuel out of children's reach.
- Refuel generator in a well-vented area. Do not fill fuel tank in the dark. Do not refuel while engine is running. Unhook all electrical loads and shut off engine before refueling.
- Do not overfill fuel tank. Always allow room for fuel to expand. If you overfill tank, fuel can overflow onto hot engine. This can cause fire or explosion. After refueling, tightly close fuel tank cap.
- Do not spill fuel. Fuel or fuel vapor may ignite. If fuel spills, make sure area is dry before starting engine.
- Never smoke in refueling area. Never allow open flames or sparks in area.
- Store fuel in approved container. Store fuel in a well-vented area free of open flames or sparks.

Use clean, fresh, unleaded gasoline. Use gasoline with octane rating of 86 or higher. Service station gasoline pumps should display the octane rating. Using gasoline with lower octane level could damage engine. Avoid getting dirt, dust, or water in fuel tank. Do not mix oil with gasoline.

See engine owner's manual for more information.

MASTER[®]

PORTABLE GASOLINE GENERATORS

BATTERY

(Models MGH5000EIE and MGH6500AIE)

⚠ WARNING: Battery gives off explosive gases. Keep sparks, flames, and cigarettes away. Do not remove or install battery cables when engine is cranking or running. Only service or use battery in a well-vented area.

⚠ WARNING: Battery contains sulfuric acid. Contact with skin or eyes may cause severe burns. Do not tilt generator with battery installed. Tilting could cause battery acid to spill. Wear protective clothing and face shield when servicing. Keep out of children's reach.

- If battery acid gets on your skin, wash with water.
- If battery acid gets in your eyes, flush with water at least 15 minutes. Call a doctor at once. Battery acid is poisonous.
- If swallowed, drink large amounts of water or milk. Follow with milk of magnesia or vegetable oil. Call a doctor at once.

⚠ CAUTION: If you remove battery, insulate the red, positive (+) battery cable terminal. Insulate with electrical tape. Exposed terminal may spark when generator runs.

IMPORTANT: Make sure battery connections are the correct polarity. Electric start generators use negative ground, 12-volt DC starting system.

Models MGH5000EIE and MGH6500AIE have an electric starter. A battery is not supplied with generator. You must provide a 12-volt, 32-amp-hour battery. The positive and negative battery cables are supplied with generator. You must install these cables before mounting battery.

Always wear safety glasses when working with battery. Make sure battery terminals are clean. Make sure cable connections are tight.

Always shut down engine before removing or attaching battery cables. Always remove the negative (-) cable first. Always attach negative (-) cable last.

INSTALLING BATTERY CABLES TO ENGINE

1. Attach the red, positive (+) battery cable to the starter solenoid on engine (see Figure 8). This cable is factory installed.

⚠ CAUTION: Do not over tighten positive terminal on starter solenoid. Positive terminal could rotate and cut into negative terminal, causing a short.

2. Attach the black, negative (-) battery cable to the engine block. Use the bolt, nut, and two washers provided with the battery cables. Use long mounting hole on opposite side of engine from starter solenoid. Attach cable as shown in Figure 9.

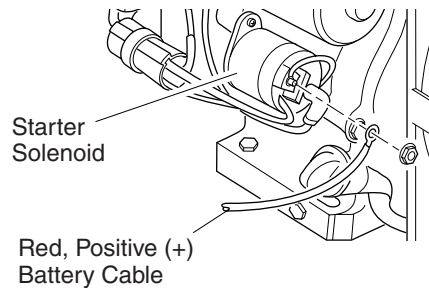

Figure 8 - Connecting Red, Positive (+) Battery Cable to Engine Starter Solenoid (Model MGH6500AIE Shown)

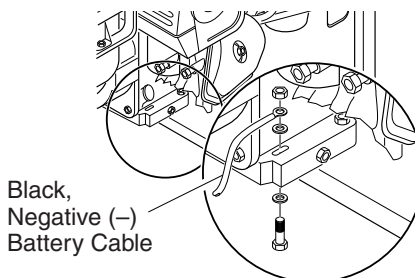

Figure 9 - Connecting Black, Negative (-) Battery Cable to Engine Block (Model MGH6500AIE Shown)

MOUNTING BATTERY TO GENERATOR

1. Secure battery to generator by battery hold-down system. This system consists of the battery mounting bracket, hook bolts, and nut (see Figure 10).
2. Locate the red, positive (+) battery cable from starter solenoid. Connect it to the positive (+) battery terminal (see Figure 11).
3. Locate the black, negative (-) battery cable attached to engine block. Connect it to the negative (-) battery terminal (see Figure 11).
4. Check battery before starting engine. Make sure fluid levels are full. Make sure battery is charged.

See engine owner's manual for more information.

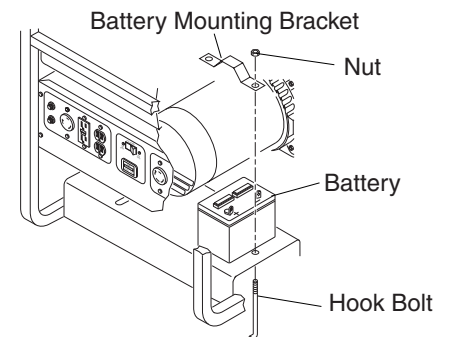

Figure 10 - Battery Hold-Down System (Model MGH6500AIE Shown)

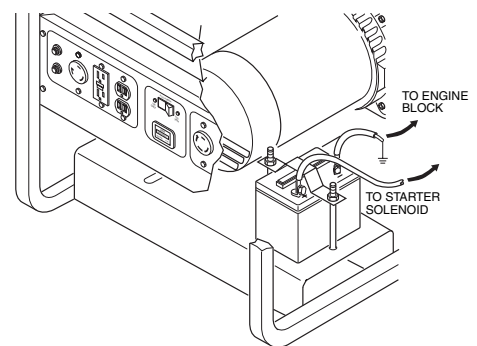

Figure 11 - Connecting Positive and Negative Cables to Battery (Model MGH6500AIE Shown)

OWNER'S MANUAL

EXTENSION CORDS

Only use grounded extension cords. Be sure to use extension cord with proper wire gauge size. See chart below.

Recommended Minimum Wire Gauges (AWG) for Extension Cords

Ampere Load	AWG for Length of Cord in Feet		
	50'	100'	150'
2	18	18	18
3	18	18	18
4	16	16	16
5	16	16	16
6	16	16	14
8	16	14	12
10	16	14	12
12	14	14	12
14	14	12	10
16	12	12	10
20	10	10	8

GENERATOR GROUNDING

⚠ WARNING: You must properly earth-ground generator before starting. This will help guard against deadly electric shock. Only use grounded plugs with generator. Only use grounded extension cords. Only use three-wire or double-insulated power tools.

Grounding generator helps prevent electric shock from a ground fault condition. Locate ground lug on roll cage (see Figure 12). Attach a #10 stranded-copper ground wire to ground lug. Drive grounding point into ground. Grounding point can be a stake, grounding rod, or pipe. Grounding point should be copper or brass. Attach ground wire to grounding point. You must supply the ground wire and grounding point. These do not come with generator. Follow the *National Electrical Code* and all state and local codes. Consult your power company or a licensed electrician.

⚠ WARNING: For a grounding point, do not use metal pipe being used to carry combustible materials or gases.

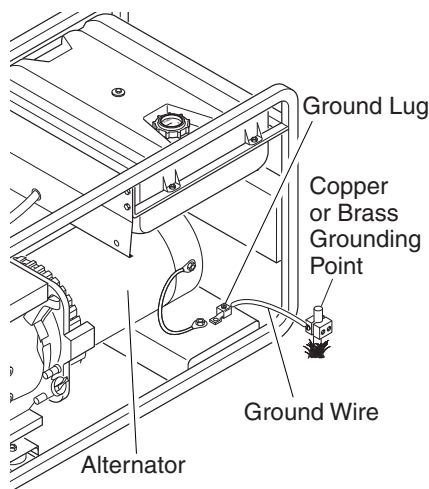

Figure 12 - Grounding Generator (Model MGH4000D Shown)

STANDBY INSTALLATION TO HOME OR BUILDING

⚠ WARNING: Have standby installation performed by a skilled, licensed electrician. Do not let anyone else wire into a utility circuit. Personal injury, equipment damage, or damage to home could occur.

IMPORTANT: This generator will not power your entire home. Most home utility electric service is more than 60 amps. This will exceed generator output. Only power needed items during a power outage. Make sure total wattage of electrical load does not exceed rated wattage of generator.

You may need to use this generator as a standby power source. During a power outage, the generator will power selected items in a building. Have generator and additional wiring installed by a skilled, licensed electrician. This is not a do-it-yourself job. Follow all local codes.

⚠ WARNING: The electrician must install a double-throw transfer switch. This isolates existing electrical circuits from the utility power line. If not isolated, generator output will back-feed into utility power line. This may electrocute a power company line repair person.

MASTER[®]

PORTABLE GASOLINE GENERATORS

DETERMINING ELECTRICAL LOAD FOR GENERATOR

You must decide what electrical load your generator can power. Do this before using generator. Use the following four-step method. It will help you select a load that is not too large. Make sure total wattage of all electrical loads does not exceed rated wattage of generator. For rated wattage of your generator, see *Specifications*, page 5. Electric motors present a special problem when figuring load. Read Step 3 carefully.

1. Make two lists of items you want powered by generator. List all motors and motor powered appliances in one. List all lights, small appliances, etc. in the other. For standby service to home or building, only include items you must power.
2. Enter running watts of each item except motors. The light bulb or appliance nameplate lists its wattage. Remember, 1KW = 1000 watts. *Note:* The nameplate may not list wattage. It may only list volts and amps. The formula for finding wattage is: Volts x Amps = Watts. For example: An appliance nameplate states 3 amps at 120 volts. 3 amps x 120 volts = 360 watts.
3. Electric motors present a special problem. They require up to three-times their rated wattage to start. Chart 2, below, shows starting watts for different size motors. For example: an electric motor nameplate states 5 amps at 120 volts. 5 amps x 120 volts = 600 watts running. Multiply this figure by 3. This will show the starting watts needed. 600 watts x 3 = 1800 watts to start. When figuring the generator load for motors, you must use the starting watts figure.

Do not use the running watts figure. *Note:* Some motors require nearly the same wattage to run as to start. These items include saws, drills, hair dryers, and food mixers. See Chart 1 for typical appliance wattage examples.

4. Add watts and starting watts of all items. This total must not be larger than the rated wattage of your generator. It is a good idea to have up to 25% extra capacity for future needs or extra equipment.

Typical Electric Appliance Wattages

Chart 1

Equipment	Running Watts	Starting Watts
Light bulb (100W)	100	100
Radio	150	150
Fan	200	600
Television	400	400
Furnace fan (1/3 hp) with blower	600	1800
Vacuum cleaner	600	750
Sump pump (1/3 hp)	700	2100
Refrigerator/freezer	800	2400
6" Circular saw	800	1000
Floodlight	1000	1000
1/2" Drill	1000	1250
Toaster	1200	1200
Coffee maker	1200	1200
Skillet	1200	1200
14" Chain saw	1200	1500
Water well pump (1/2 hp)	1000	3000
Hot plate/range (per burner)	1500	1500
10" Table saw	2000	6000
Water heater (storage-type)	5000	5000

Chart 2

Motor HP Rating	Approximate Running Watts	Approximate Starting Watts*			
		Universal Motors (small appliance)	Repulsion Induction Motors	Capacitor Motors	Split Phase Motors
1/8	500	625	1100	1500	2250
1/4	700	875	1550	2100	3150
1/3	800	1000	1750	2400	3600
1/2	1100	1375	2400	3300	4950
3/4	1400	1750	3100	4200	x
1	1700	2125	3750	5100	x
1 1/2	2100	2625	4620	6300	x
2	2450	3075	5400	7350	x
3	3600	x	7900	10800	x

* – Always use starting watts, not running watts, when figuring correct electrical load.
 x – Motors of higher horsepower are not generally used.

OWNER'S MANUAL

OPERATION

GENERAL INFORMATION

This generator is not large enough to power your entire home. Do not connect generator to any existing electrical circuits. Plug items directly into generator receptacles. Do not exceed amperage rating of receptacles. Only use grounded cords.

⚠ DANGER: Use only in well-vented areas. Make sure area has plenty of free-moving, fresh, outside air. Never run generator in an enclosed or confined area. Never run generator inside occupied building. Engine exhaust contains poisonous carbon monoxide gas. Overexposure will cause loss of consciousness and will lead to death.

⚠ DANGER: Never connect generator to any existing electrical circuits. The generator output will back-feed into the utility power line. This may electrocute a power company line repair person. Also, if generator is powering electrical circuits, the chance of an electrical fire exists.

Note: We supply the engine owner's manual with generator. Refer to that manual for questions concerning engine operation.

USING RECEPTACLE

Note: Do not exceed amperage rating of receptacles. Exceeding rating will trip receptacle circuit breaker.

Use receptacles properly. Improper use could damage generator. Use only grounded extension cords. Power only grounded or double-insulated items. Do not overload receptacles. All generators (except models HWI3000A, MGH3000GA, and MGH3000A) have the following receptacles (see Figure 13):

- 120V, 15-amp GFCI duplex receptacle
- 120V, 30-amp twist-lock receptacle
- 120/240V, 20 or 30-amp twist-lock receptacle
- 120V, 15-amp duplex receptacle

Model HWI3000A has only the 120V, 20-amp duplex receptacle.

Models MGH3000GA and MGH3000A have only the 120V, 15-amp GFCI duplex receptacle.

120V, 15-Amp GFCI Duplex

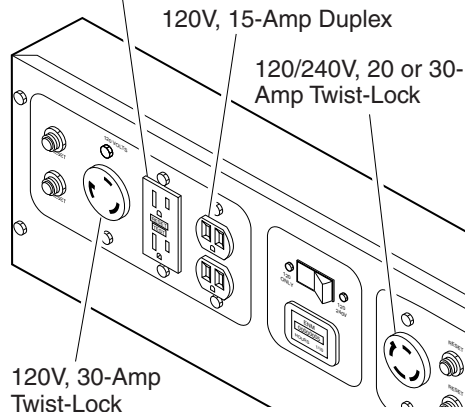

Figure 13 - Receptacle Locations

POWER CORD AND PLUG REQUIREMENTS

120V, 30-amp twist-lock receptacle

- NEMA L5-30P plug
- Three-wire, 30-amp cord

120/240V, 20 or 30-amp twist-lock receptacle

- NEMA L14-20P (20-amp) or L14-30P (30-amp) plug
- Four-wire, 20-amp or 30-amp cord

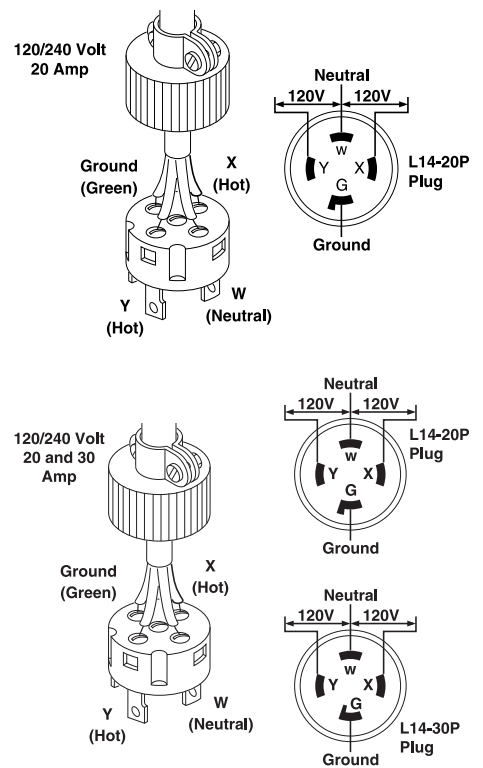

Figure 14 - Cord and Plug Configurations

Continued

MASTER[®]

PORTABLE GASOLINE GENERATORS

OPERATION

Continued

PRESTART

Operate generator on a firm, dry, and clean surface. The surface must be level. Protect generator from heavy dust, sand, dirt, rain, or snow. Do not locate generator near standing water and snow. Make sure area is well-vented.

⚠ WARNING: Only responsible adults should use generator. Never let anyone operate generator without proper instructions.

Note: If oil level is too low, oil alert system will keep engine from starting (see *Oil Alert System*, page 6). Make sure oil level is full before starting. See *Engine Oil*, page 7.

Before starting the engine, disconnect all electric loads from generator.

STARTING

IMPORTANT: The engine speed is preset. The throttle is locked in preset position. Do not adjust throttle. Preset position lets engine run at 3600 RPM under load. The engine must maintain 3600 RPM for generator to create correct voltage. Running engine at lower speeds will damage generator and powered items.

IMPORTANT: Never start generator with electrical loads connected. Start engine before adding electrical loads.

1. Make sure gasoline tank is full. See *Fuel*, page 7 for fuel information.
2. Move fuel valve lever to the ON position (see Figure 15).

Choke Lever (Closed Position)

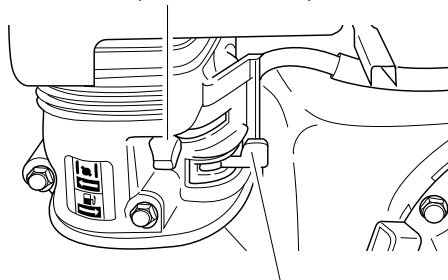

Fuel Valve Lever (ON Position)

Figure 15 - Fuel Valve Lever On, Choke Lever Closed (Model MGH4000D Shown)

3. Move choke lever fully to the left. This closes the choke.

Note: You may not need to close choke if engine is warm or air temperature is high.

4. Start the engine.

A. Recoil Starter

Move engine lever or turn engine switch to the ON position (see Figure 16). Remove slack from starter rope by lightly pulling starter grip. Next, pull starter rope briskly.

IMPORTANT: Do not let starter grip snap back against engine. Return it gently. This will prevent damage to starter.

Note: If engine does not start, check the oil in the crankcase. Add oil as necessary. Be sure engine is on a level surface. See *Oil Alert System*, page 6.

B. Electric Starter (Models MGH5000EIE and MGH6500AIE Only)

Turn the engine switch to the START position (see Figure 17). Hold it there until engine starts. When engine starts, let switch return to the ON position.

IMPORTANT: Do not use electric starter more than five seconds. Starter motor damage may occur. If engine fails to start, release the switch and wait ten seconds. After ten seconds, try starting again.

Note: If engine does not start, check the oil in the crankcase. Add oil as necessary. Be sure engine is on a level surface. See *Oil Alert System*, page 6.

5. As engine warms up, slowly move choke lever fully to the right (see Figure 18). This opens the choke.



Figure 16 - Engine Switch In ON Position (All Models Except MGH5000EIE and MGH6500AIE)

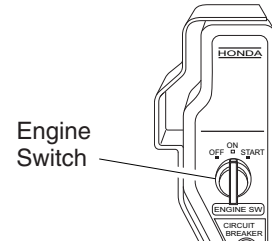

Figure 17 - Engine Switch (Models MGH5000EIE and MGH6500AIE Only)

Choke Lever (Open Position)

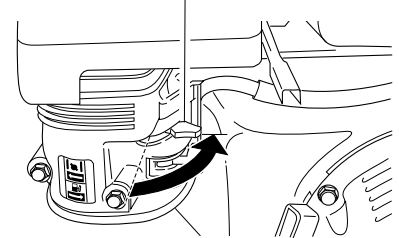

Figure 18 - Choke Lever Opened (Model MGH6500AIE Shown)

AUTO-IDLE OPERATION

IMPORTANT: Never start engine with electrical loads connected. Start engine before adding electrical loads.

1. If engine is cold, turn the Auto-Idle switch OFF (see Figure 19).
2. Start engine. Allow engine to warm up with no load for five minutes.
3. Turn Auto-Idle switch ON. Engine will slow to idle speed. Engine idle speed is preset. Idle speed adjustment should not be necessary.
4. Operate generator according to specifications outlined in owner's manual.
5. Engine will automatically increase to normal operating speed when you plug load into any generator outlet.

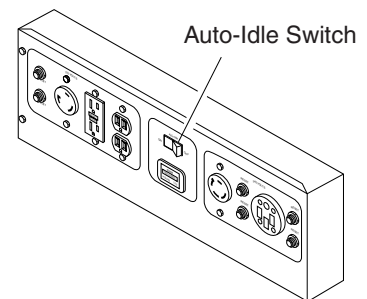

Figure 19 - Control Panel

6. The Auto-Idle system should be turned OFF when generator is shut down.

OPERATION

Continued

Adjusting the Idle Speed

IMPORTANT: Adjust the idle speed only:

- If the idle speed becomes too high.
 - If the engine idle speed will not regulate (engine idles and speeds up again and again).
1. Turn Auto-Idle switch OFF. Start engine. Allow engine to warm up with no load for five minutes.

⚠ WARNING: Always set the idle speed before turning on the Auto-Idle. If idle speed is not set, the larger resistor on the control board may become hot. Heat from the resistor may damage the protective coating on the control board.

2. Remove engine linkage cover (Models MGH4000DI, MGH5000EI, MGH5000EIE, and MGH6500AIE).
3. Push plunger into solenoid body to manually engage solenoid and set idle speed.
4. Loosen nut that holds the solenoid mounting bracket to the generator (Models MGH4000DI, MGH5000EI, MGH5000EIE, and MGH6500AIE. See Figure 20).
5. Slowly pull solenoid bracket away from engine.
6. With a volt meter, check the no-load output voltage at the 120-volt duplex receptacle. At proper idle speed (2680 minimum RPM) the meter should read 50-60 volts. Lower settings will cause the Auto-Idle to not operate properly.

7. After reaching proper idle speed, tighten nut to secure solenoid mounting bracket (Models MGH4000DI, MGH5000EI, MGH5000EIE, and MGH6500AIE (see Figure 20).
8. Turn Auto-Idle switch ON. Make sure solenoid is engaged. When engaged, the plunger is pulled back into the solenoid.
9. If the engine speed is too slow, the engine will want to "hunt" or speed up and slow down repeatedly. When this occurs, increase engine speed by adjusting throttle stop screw on carburetor (refer to Carburetor Adjustment in Honda Engine Manual).
10. Replace the engine linkage cover (Models MGH4000DI, MGH5000EI, MGH5000EIE, and MGH6500AIE).

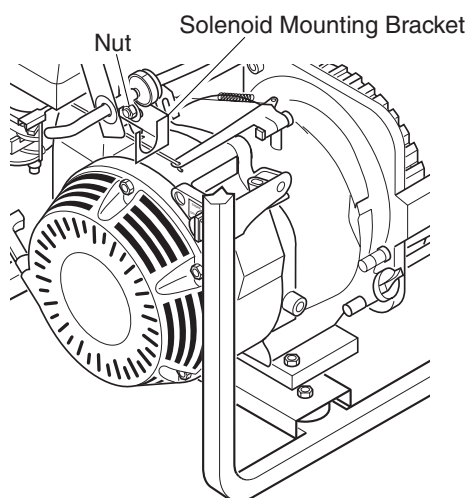

Figure 20 - Solenoid Bracket Location, Models MGH4000DI, MGH5000EI, MGH5000EIE, and MGH6500AIE Only

HIGH ALTITUDE OPERATION

This generator will not perform well at high altitudes without proper adjustment. See engine owner's manual for details.

ADDING ELECTRICAL LOADS

IMPORTANT: Do not overload generator. Make sure total wattage of all electrical loads does not exceed rated wattage of generator. Overloading may shorten generator life. It could also cause internal damage to generator. Overloading will trip circuit breaker.

IMPORTANT: (All models except HWI3000A, MGH3000A, and MGH6500AIE) Keep full power selector switch in the 120 VOLT ONLY position if only powering 120V items. Only move switch to 120/240 VOLT position if powering 240V items.

1. Check items to be powered. Their nameplate lists their wattage ratings.
Note: The wattage ratings for some electrical motors are misleading. They may require up to three-times their rated wattage to start. You must figure total electrical load wattage. Make sure total wattage of all electrical loads does not exceed rated wattage of generator. See *Determining Electrical Load For Generator*, page 10.
2. Start engine. Let engine reach full speed.
3. Connect electrical loads one at a time. If the load consists of electric motors, start them first. Always start the largest first. Start each motor individually.

DISCONNECTING ELECTRIC LOADS

Remove electrical loads one at a time. Remove voltage sensitive items first. Voltage sensitive items include TVs, VCRs, and other home electronic items.

MASTER[®]

PORTABLE GASOLINE GENERATORS

OPERATION

Continued

STOPPING ENGINE

IMPORTANT: The engine speed is preset. The throttle is locked in preset position. Do not adjust throttle.

Follow the steps below to stop engine.

1. Remove all electrical loads from generator (see *Disconnecting Electrical Loads*). Remove electrical loads one at a time.
2. Let engine run for two or three minutes after removing electrical loads. This lets engine cool slightly.
3. Turn engine switch to the OFF position (see Figure 21).
4. Turn fuel valve lever off. Do this by moving valve lever fully to the left (see Figure 22).

Models HWI3000A, MGH3000GA, MGH3000A, MGH4000D, MGH4000DI, MGH5000E, and MGH5000EI

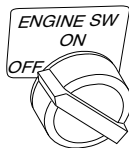

Models MGH5000EIE and MGH6500AIE

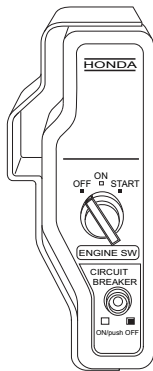

Figure 21 - Engine Switch In OFF Position

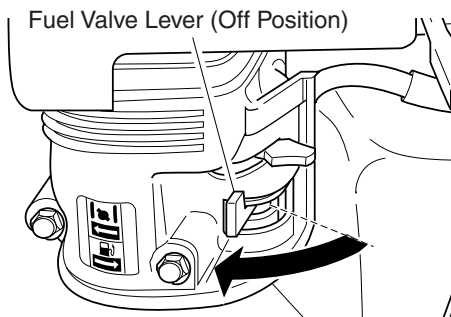

Figure 22 - Fuel Valve Lever Off (Model MGH6500AIE Shown)

MAINTENANCE AND REPAIRS

WARNING: Only a qualified electrical service person should service and repair the alternator on this generator. Use only factory approved replacement parts.

CAUTION: The engine speed is preset. The throttle is locked in preset position. Do not adjust throttle. Preset position lets engine run at 3600 RPM under load. The engine must maintain 3600 RPM for generator to create correct voltage. Running engine at lower speeds will damage generator and powered items.

CAUTION: Shut off generator before performing maintenance.

IMPORTANT: Keep generator level when servicing. Never turn generator upside down or stand it on end to service.

Note: We supply the engine owner's manual with generator. Refer to that manual for questions concerning engine maintenance and repairs.

Non-engine parts require little maintenance. Keep generator clean. Use a damp cloth to clean outside surfaces. Never use water to clean generator. Water can cause damage to internal parts. Use vacuum to clean air inlet and outlet louvers of alternator.

STORAGE

WARNING: Remove all fuel from fuel tank before storing generator. Store fuel in approved container. Store fuel in a well-vented area free of open flames or sparks.

WARNING: The muffler becomes very hot during operation. The muffler remains hot for a while after shutdown. Let engine cool before storing.

IMPORTANT: Keep generator level while in storage. Never store generator upside down or standing on end.

Note: We supply the engine owner's manual with generator. Refer to that manual for questions concerning engine storage.

Use a fuel additive, such as STA-BIL[®] or an equivalent, when storing generator with fuel in fuel tank. This will minimize fuel gum deposits from forming in engine.

Cover and store generator in a clean, dry place. Do not expose generator to extreme high or low temperatures during storage.

OWNER'S MANUAL

SERVICING THE ENGINE

Honda parts and services should be handled by your nearest authorized engine service firm. Check the yellow pages of your telephone directory under the listing:

Engines Gasoline, Honda

or visit:

www.honda-engines.com

or call Honda direct:

1-800-426-7701

TECHNICAL SERVICE

You may have further questions about assembling, operating, or maintaining this product. If so, you can visit our Technical Service web site at www.desatech.com or contact our Technical Service Department at 1-800-858-8501 (English Only). You may also write to:

DESA Specialty Products™
ATTN: Technical Service Specialty Products
P.O. Box 90004
Bowling Green, KY 42102-9004

When contacting DESA Specialty Products™, have ready

- Your Name
- Your Address
- Your Phone Number
- Model Number of Product
- Serial Number
- Date of Purchase (Include copy of receipt for written requests).

TROUBLESHOOTING

Note: For additional help, visit DESA International's technical service web site at www.desatech.com.

⚠ WARNING: Only a qualified electrical service person should service and repair generator. Use only factory approved replacement parts.

Note: See engine owner's manual for engine troubleshooting.

OBSERVED PROBLEM

POSSIBLE CAUSE

REMEDY

No voltage when starting generator with no electrical load

1. Defective capacitor
2. Winding short circuit or loose connections
3. Defective rotor diode
4. Loss of residual magnetism

1. Replace capacitor
2. Check resistance of coils (see *Electrical Component Specifications*, page 16)
3. Replace both diodes on rotor
4. Apply 12-volt battery to capacitor terminals for 2-3 seconds

Voltage is less than normal voltage with no electrical load

1. Engine speed too low
2. Defective rotor diode
3. Partial short circuit in winding
4. Defective capacitor

1. Set engine speed to 3720 RPM (62 Hz) with no load
2. Replace both diodes on rotor
3. Check resistance of coils (see *Electrical Component Specifications*, page 16)
4. Replace capacitor

Voltmeter reading more than 10% high with no electrical load

1. Engine speed too high

1. Set engine speed to 3720 RPM (62 Hz) with no load

Voltmeter reading correct with no electrical load, but more than 10% low when electrical load is added

1. Defective rotor diode
2. Electrical load too high
3. Engine not running properly

1. Replace both diodes on rotor
2. Do not overload generator
3. Contact an authorized engine service center

www.desatech.com

MASTER[®]

PORTABLE GASOLINE GENERATORS

ELECTRICAL COMPONENT SPECIFICATIONS

Model	Resistance in Ohms			Capacitor, MFD 450 Volt	Diodes (2) 800 Volt
	Stator Main Winding *	Stator Exciting Winding Δ	Rotor Primary Winding \dagger		
HWI3000A, MGH3000GA, MGH3000A	1.63	5.29	4.62	14	6 Amp
MGH4000D, MGH4000DI	0.709	5.33	13.25	16	70 Amp
MGH5000E, MGH5000EI, MGH5000EIE	0.570	3.129	3.31	18	70 Amp
MGH6500AIE	.326	2.012	4.38	31.5	70 Amp

* Connect T2 (green) and T3 (black). Measure resistance between T1 (red) and T4 (yellow).

Δ Resistance between brown and white leads.

\dagger Remove diodes to check resistance.

OWNER'S MANUAL

WIRING DIAGRAMS

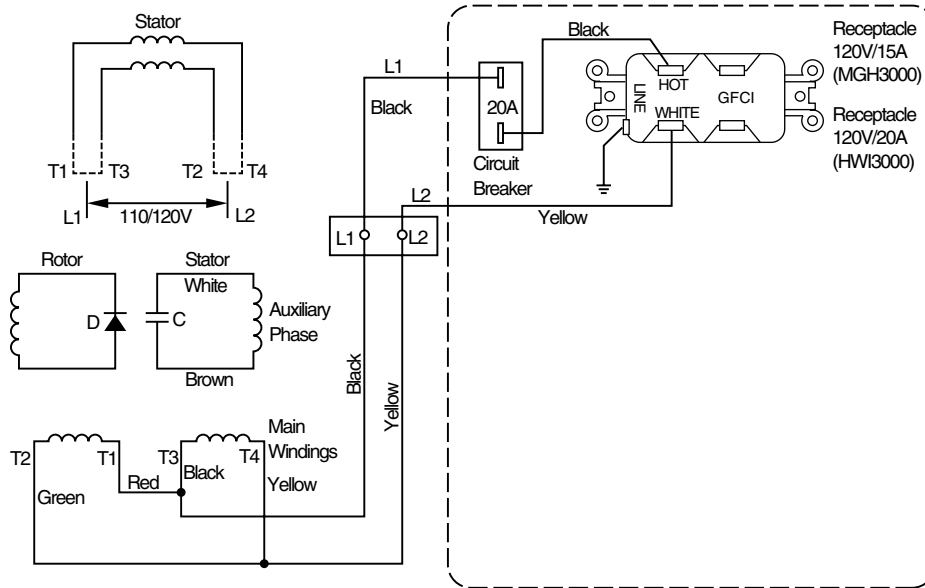

Figure 23 - Wiring Diagram, Models HWI3000A, MGH3000GA, and MGH3000A

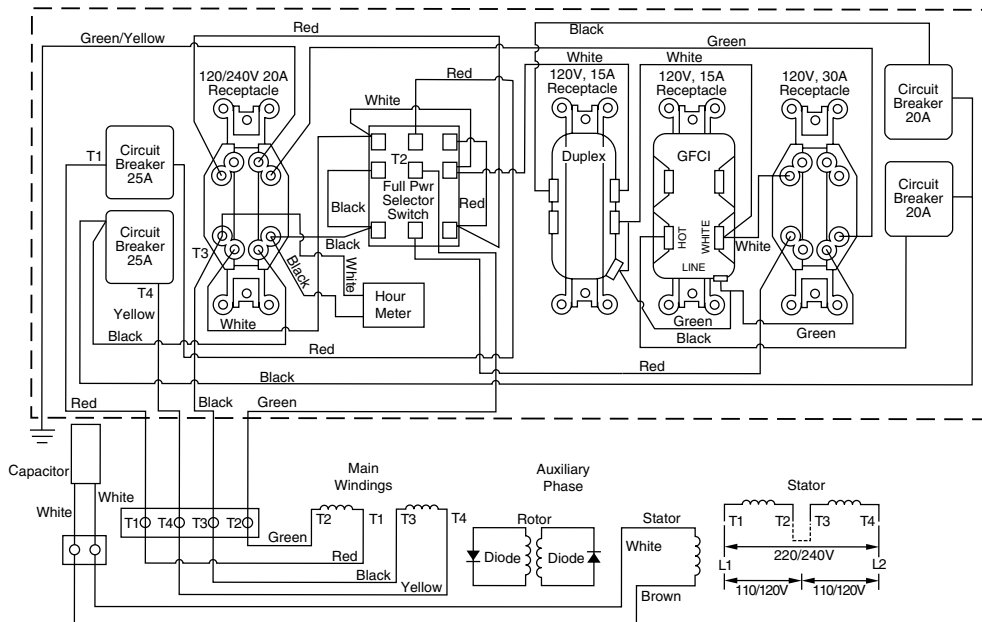

Figure 24 - Wiring Diagram, Models MGH4000D and MGH5000E

Continued

MASTER[®]

PORTABLE GASOLINE GENERATORS

WIRING DIAGRAMS

Continued

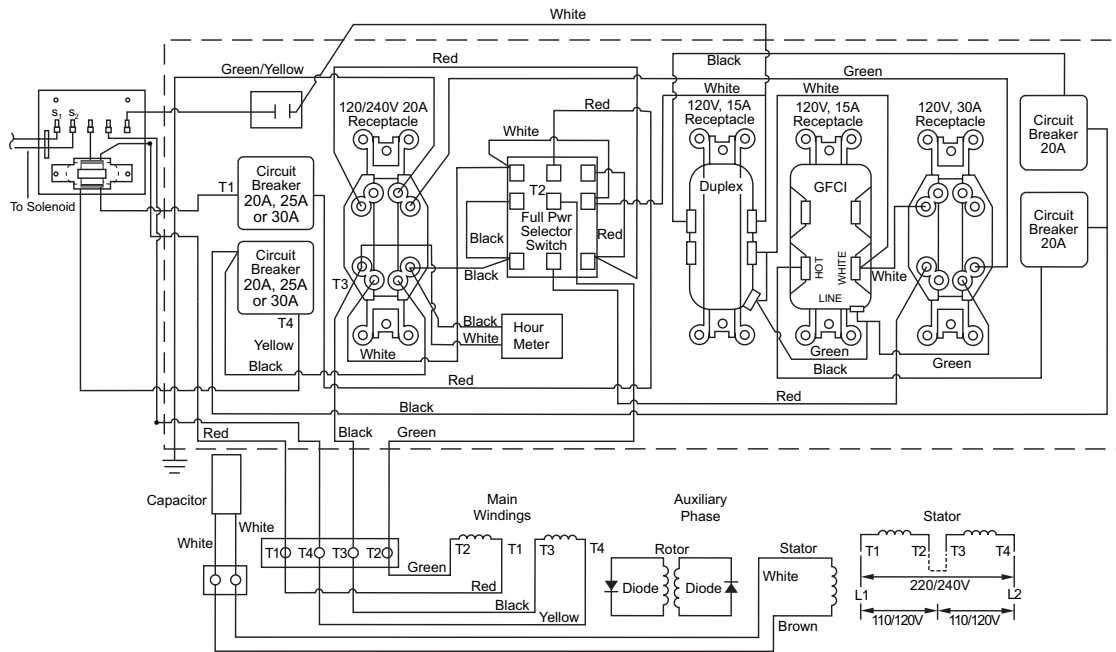

Figure 25 - Wiring Diagram, Models MGH4000DI, MGH5000EI, and MGH5000EIE

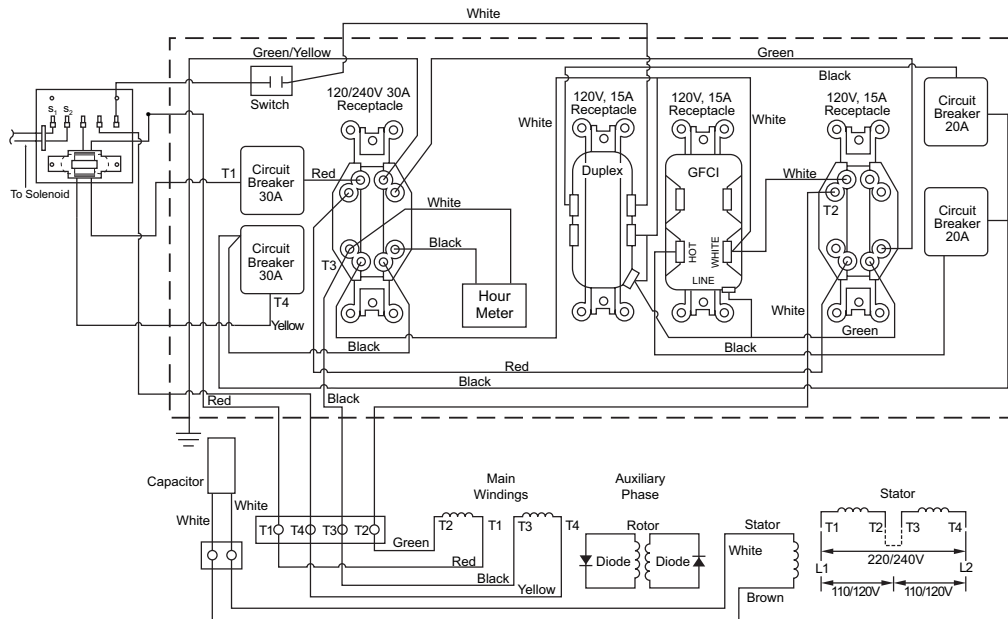

Figure 26 - Wiring Diagram, Model MGH6500AIE

OWNER'S MANUAL

ILLUSTRATED PARTS LIST

For Model HWI3000A, MGH3000GA, and MGH3000A Alternator Assembly

This list contains replaceable parts used in your generator. When ordering parts, follow the instructions listed under *Replacement Parts* on page 32 of this manual.

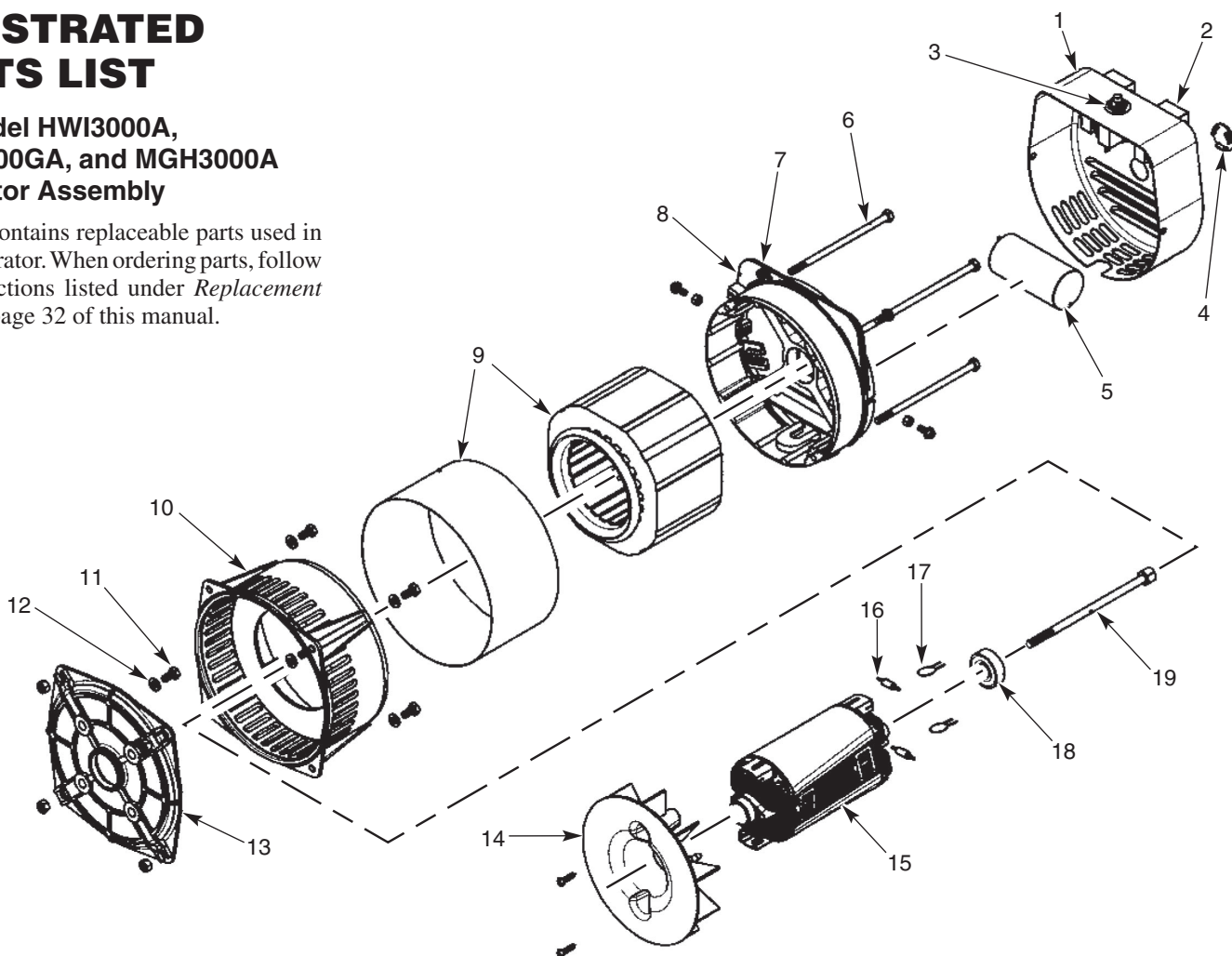

KEY NO.	PART NUMBER	DESCRIPTION	QTY.	KEY NO.	PART NUMBER	DESCRIPTION	QTY.
1	118054-01	Alternator Assembly*		11	26327006	Bolt, 5/16-24 x 5/8"	4
2a	118703-01	End Cover	1	12	WLE-5	Lock Washer, 5/16"	4
	100445-01	120V, 15A Duplex (GFCI) Receptacle (MGH3000GA, MGH3000A) †	1	13	118713-01	Flange	1
2b	104201-01	120V, 20A Duplex (GFCI) Receptacle (HWI3000A) †	1	14	118706-01	Fan	1
3	22616009	Circuit Breaker, 20 Amp †	1	15	**	Rotor	1
4	118714-01	Shaft End Cap	1	16	118708-01	Diode	2
5	118712-01	Capacitor	1	17	118709-01	Varistor	2
6	118710-01	Stator Bolt	4	18	118707-01	Bearing	1
7	17587000	Grounding Lug	1	19	118711-01	Draw Bolt	1
8	118704-01	Bearing Housing	1	PARTS AVAILABLE - NOT SHOWN			
9	**	Stator	1		118674-01	Safety Information Decal	1
10	118705-01	Fan Bracket	1		118674-02	Safety Information Decal	1
					099867-02	Operation Decal	1

† Includes fastening hardware.

* Includes reference numbers 1 through 22.

** Parts not available. Included in alternator assembly.

MASTER

PORTABLE GASOLINE GENERATORS

ILLUSTRATED PARTS LIST

For Models MGH4000D, MGH4000DI, MGH5000E, MGH5000EI, MGH5000EIE, MGH6000D, MGH6000DI, MGH6500AIE Alternator Assembly

This list contains replaceable parts used in your generator. When ordering parts, follow the instructions listed under *Replacement Parts* on page 32 of this manual.

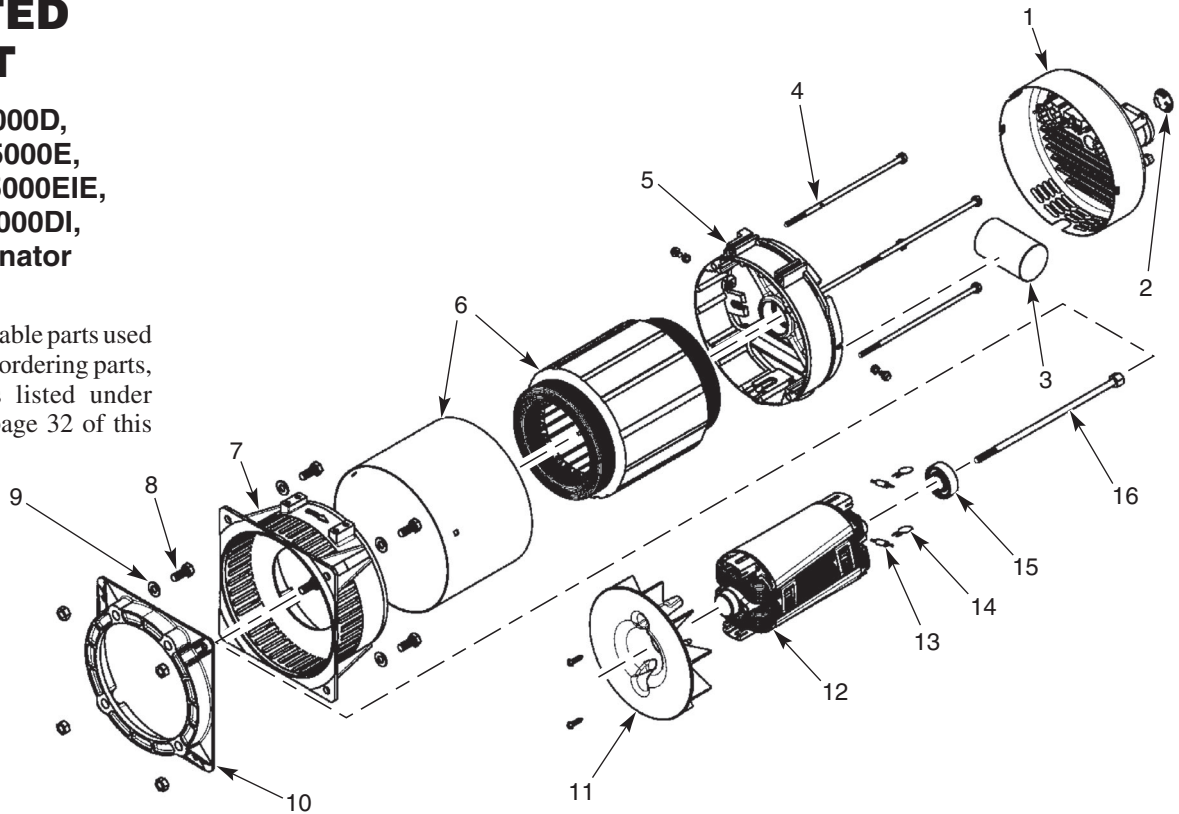

KEY NO.	PART NUMBER FOR MODEL			DESCRIPTION	QTY.
	MGH4000D MGH4000DI	MGH5000E MGH5000EI MGH5000EIE	MGH6500AIE		
1	118055-01	118055-02	118055-03	Alternator Assembly	1
2	118782-01	118782-01	118782-01	End Cover	1
3	118714-01	118714-01	118714-01	Shaft End Cap	1
4	118712-01	118783-01	118783-02	Capacitor	1
5	118784-01	118784-02	118784-04	Stator Bolt	4
6	118785-01	118785-01	118785-01	Bearing Housing	1
7	*	*	*	Stator	1
8	118786-01	118786-01	118786-01	Fan Bracket	1
9	26322004**	26322004**	26322004**	Bolt, 3/8-16 x 5/8"	4
10	WLE-6**	WLE-6**	WLE-6**	Lock Washer, 3/8"	4
11	118787-01	118787-01	118787-01	Flange	1
12	118788-01	118788-01	118788-01	Fan	1
13	*	*	*	Rotor	1
14	118708-01	118708-01	118708-01	Diode	2
15	118709-01	118709-01	118709-01	Varistor	2
16	118789-01	118789-01	118789-01	Bearing	1
17	118791-01	118791-02	118791-03	Draw Bolt	1

* Part not available by itself. Must purchase Alternator Assembly.

**Available at your local hardware store.

ILLUSTRATED PARTS LIST

For Model MGH3000GA Alternator Assembly

This list contains replaceable parts used in your generator. When ordering parts, follow the instructions listed under *Replacement Parts* on page 32 of this manual.

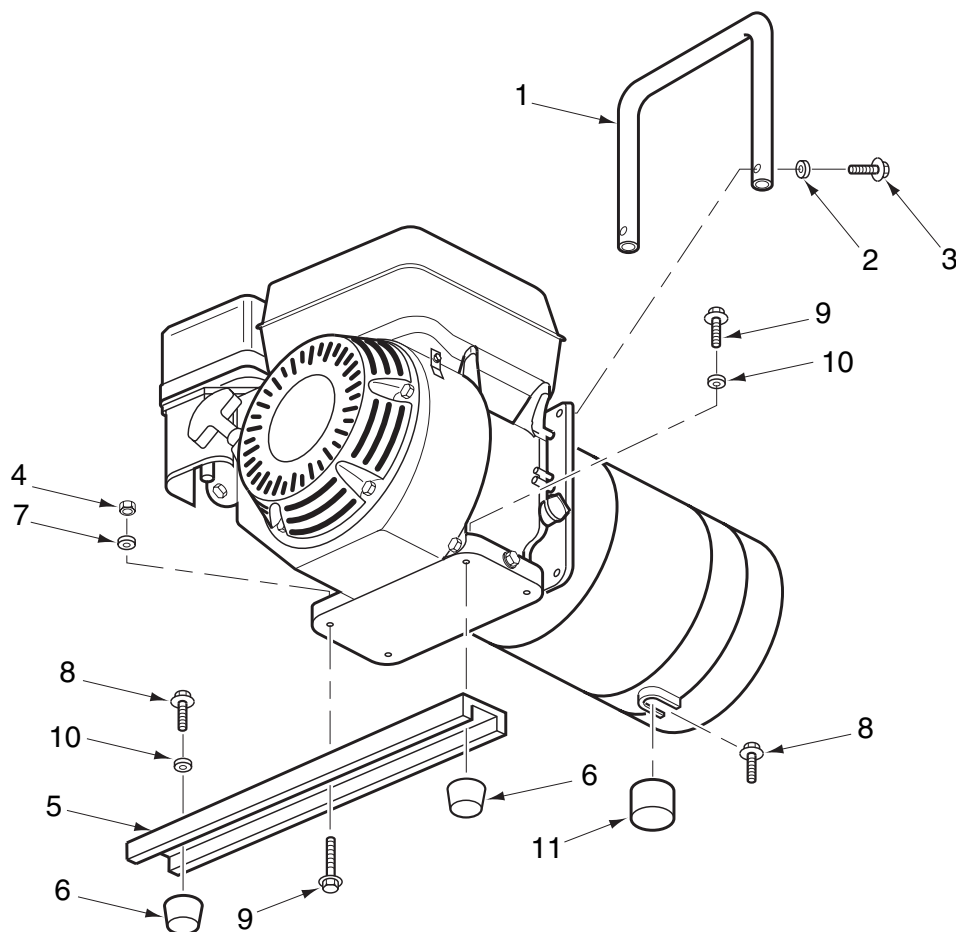

KEY NO.	PART NUMBER	DESCRIPTION	QTY.
1	118669-01	Handle (includes 2 spacers)	1
2	WLE-4	1/4" Lock Washer	2
3	099769-01	M6 x 35 Bolt	2
4	NEC-5C	5/16-18 Nut	1
5	099754-01	Engine Spreader	1
6	118821-02	Rubber Bumper	2
7	WP-5C	5/16" Flat Washer	1
8	50009402	5/16-18 x 1/2" Bolt	2
9	118790-01	5/16-18 x 1 ³ / ₈ " Bolt	1
10	WLE-5	5/16" Lock Washer	2
11	118821-01	Rubber Bumper	1

Note: Fuel tank is available from Engine Mfg. Co. only.

MASTER[®]

PORTABLE GASOLINE GENERATORS

ILLUSTRATED PARTS LIST

For Models HWI3000A and
MGH3000A Roll Cage

This list contains replaceable parts used in
your generator. When ordering parts, follow
the instructions listed under *Replacement
Parts* on page 32 of this manual.

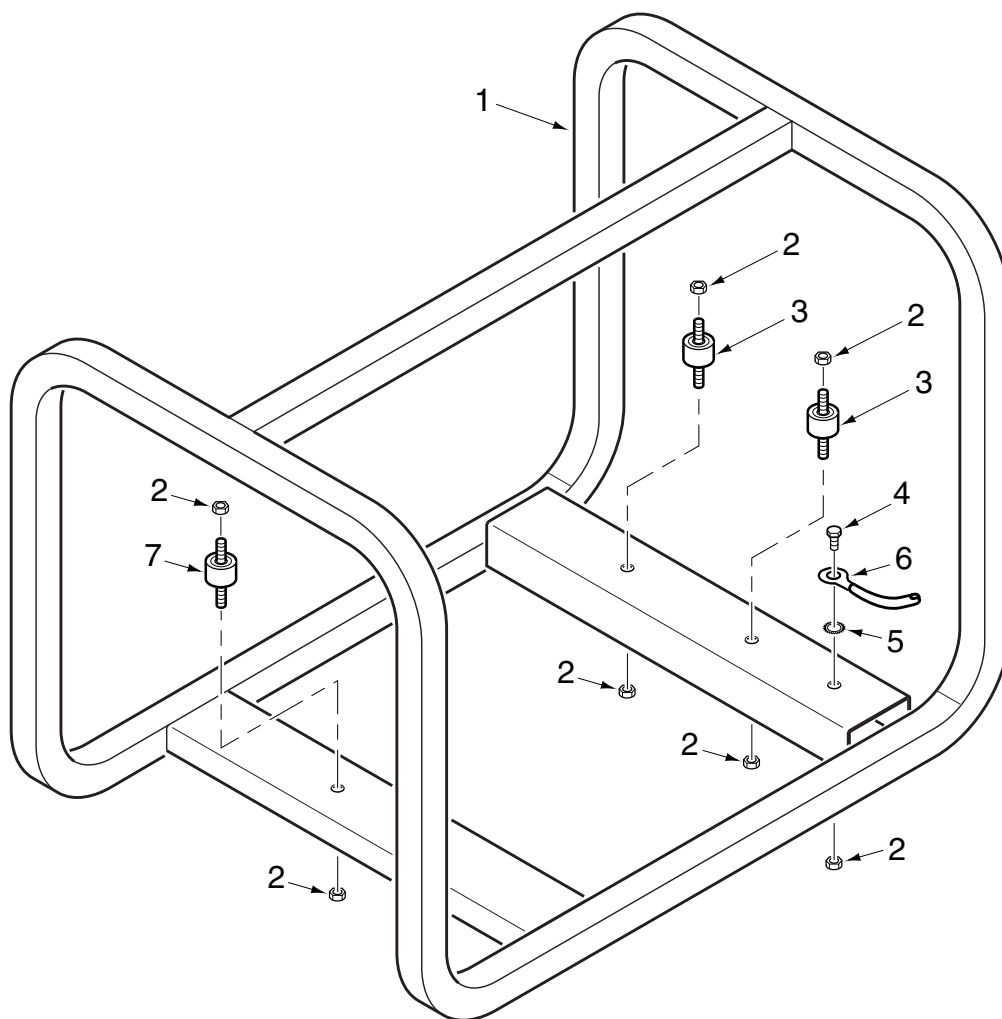

ILLUSTRATED PARTS LIST

For Models HWI3000A and MGH3000A Roll Cage

This list contains replaceable parts used in your generator. When ordering parts, follow the instructions listed under *Replacement Parts* on page 32 of this manual.

KEY NO.	PART NUMBER	DESCRIPTION	QTY.
1	118916-02	Roll Cage	1
2	NEC-5C	Lock Nut, 5/16-18	7
3	099853-03	Shock Mount	2
4	*	Bolt, 5/16-18 x 1/2"	1
5	WLE-5	Lock Washer, 5/16"	1
6	14138002	Grounding Strap	1
7	099853-02	Shock Mount	1

* Available at any hardware store.

MASTER

PORTABLE GASOLINE GENERATORS

ILLUSTRATED PARTS LIST

For Models MGH4000D,
MGH4000DI, MGH5000E,
MGH5000EI, MGH5000EIE,
and MGH6500AIE
Fuel Tank and Roll Cage

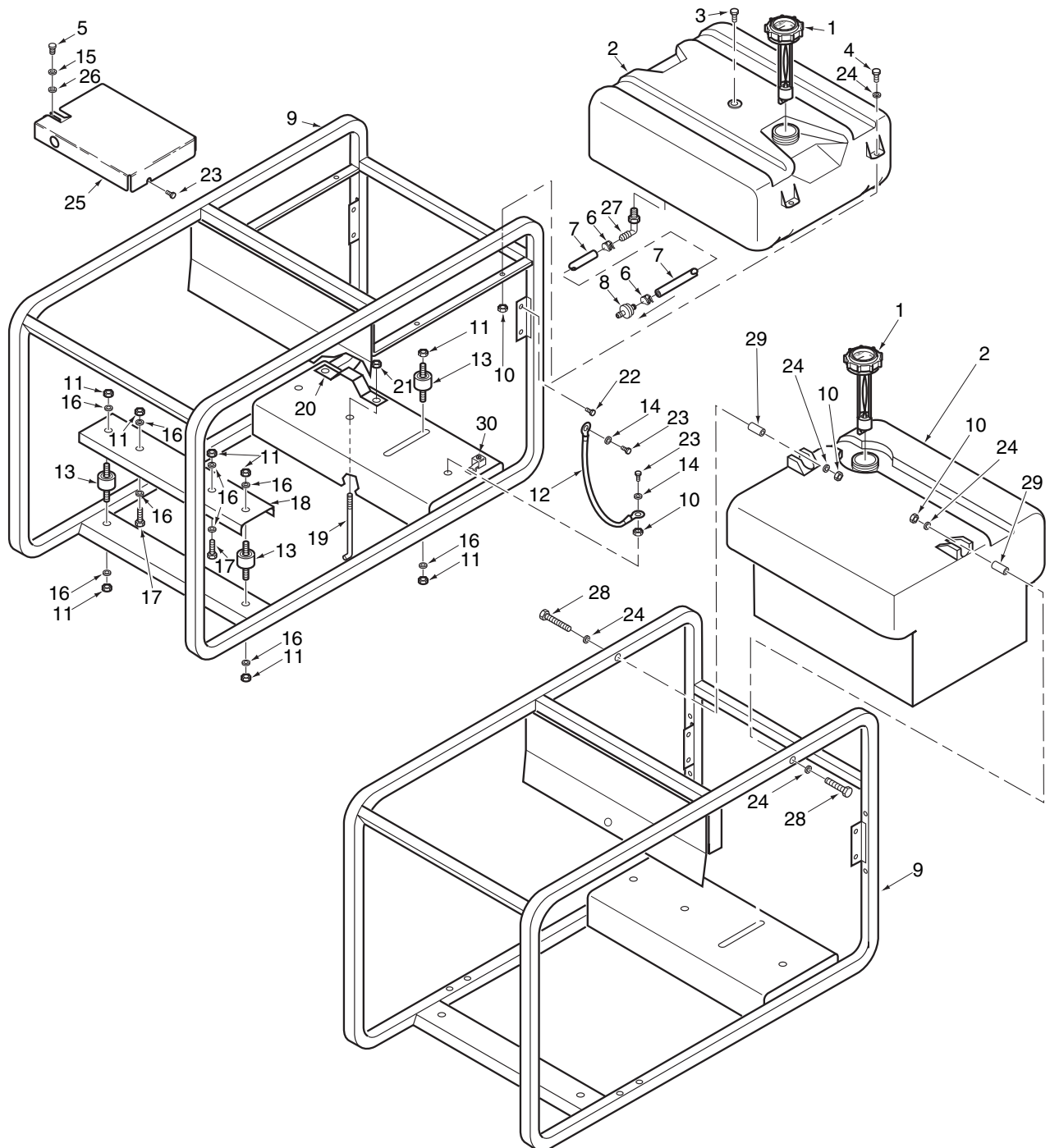

OWNER'S MANUAL

ILLUSTRATED PARTS LIST

For Models MGH4000D, MGH4000DI,
MGH5000E, MGH5000EI, MGH5000EIE, and MGH6500AIE
Fuel Tank and Roll Cage

This list contains replaceable parts used in your generator. When ordering parts, follow the instructions listed under *Replacement Parts* on page 32 of this manual.

KEY NO.	MGH4000D MGH4000DI	MGH5000E MGH5000EI MGH5000EIE	MGH6500AIE	DESCRIPTION	QTY.
1	25954000	25954001	25954001	Gas Cap/Fuel Gage	1
2	099832-01	107021-01	107021-01	Gas Tank (with 90° fitting)	1
3	25978000	—	—	Breather Assembly	1
4	HC4-8C	—	—	Screw, 1/4-20 x 1"	4
5	099701-01	099701-01	099701-01	Screw, M5 x 10	1
6	19508001	19508001	19508001	Gas Line Clamp	2
7	25985005	25985005	25985005	Fuel Line	1
8	099743-01	099743-01	099743-01	Fuel Filter	1
9	118918-01	118917-01	118917-01	Roll Cage	1
10	103880-01	—	—	Lock Nut, 1/4-20	5
	—	103880-01	103880-01	Lock Nut, 1/4-20	3
11	NEC-5C	—	—	Lock Nut, 5/16-18	8
	—	NEC-5C	NEC-5C	Lock Nut, 5/16-18	10
12	14138000	14138000	14138000	Ground Strap	1
13	099853-02	099853-02	099853-02	Shock Mounts	3
14	WLE-5	WLE-5	WLE-5	Lock Washer, 5/16"	3
15	WLI-3	WLI-3	WLI-3	Lock Washer, #10	1
16	WP-5C	—	—	Flat Washer, 5/16"	9
	—	WP-5C	WP-5C	Flat Washer, 5/16"	11
17	HC5-14C	HC5-14C	HC5-14C	Bolt, 5/16-18 x 1 3/4"	2
18	099756-01	099756-01	099756-01	Engine Spreader	1
19	—	099750-01*	099750-01	Hook Bolt, 5/16-18	2
20	—	099749-01*	099749-01	Battery Mounting Bracket	1
21	—	NEC-5C*	NEC-5C	Lock Nut, 5/16-18	2
22	100410-01	100410-01	100410-01	Sems Screw, #8-18 x 1/2"	4
23	M10908-74	M10908-74	—	Screw, 1/4-20 x 1/2"	3
	—	M10908-74*	M10908-74	Screw, 1/4-20 x 1/2"	2
24	WP-4C	WP-4C	WP-4C	Washer, 1/4"	4
25	099965-01	099965-01	099965-01	Linkage Cover	1
26	WP-3C	WP-3C	WP-3C	Washer, #10	1
27	103676-01	103676-01	103676-01	90° Fitting with barbs	1
28	—	HC4-16C	HC4-16C	Bolt, 1/4-20 X 2"	2
29	—	107110-01	107110-01	Spacer .25 X .500	2
30	17587000	17587000	17587000	Grounding Lug	1
PARTS AVAILABLE - NOT SHOWN					
	099866-02	—	—	Safety Information Decal	1
	100003-01	100003-01	—	Operation Decal	1
	—	100003-02*	100003-02	Operation Decal	1
	—	099873-01*	099873-01	Battery Cable (Positive, Red)	1
	—	099873-02*	099873-02	Battery Cable (Negative, Black)	1
	03175000	03175000	03175000	Fuel Line Grommet	3

* Only on MGH5000EIE electric start models

MASTER[®]

PORTABLE GASOLINE GENERATORS

ILLUSTRATED PARTS LIST

For Solenoid and Control Board
Assemblies and Mounting

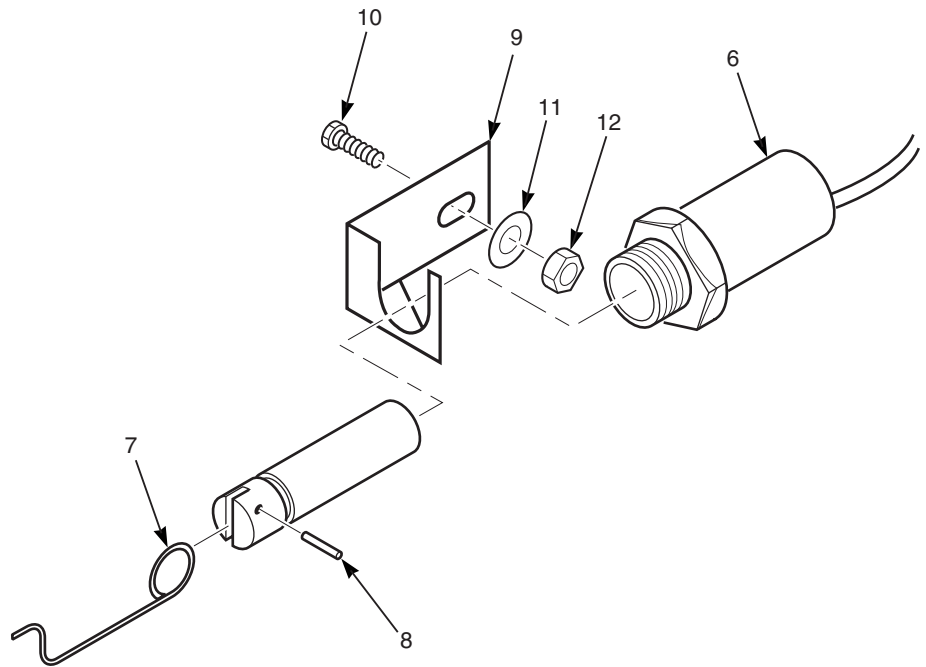

Solenoid Assembly and Mounting

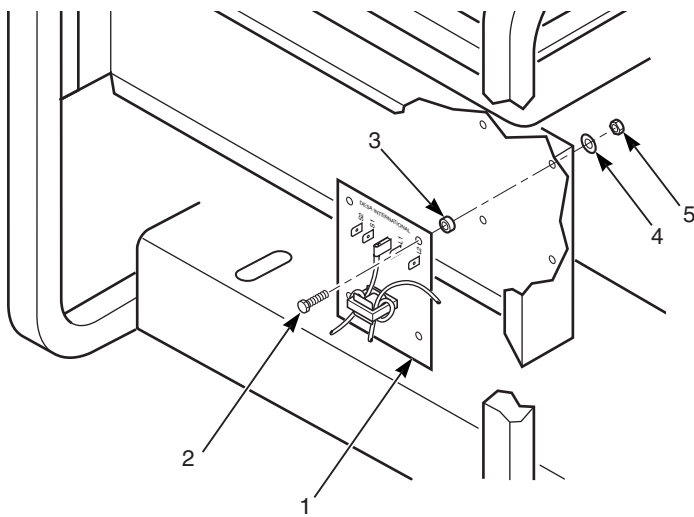

Control Board Assembly and Mounting

ILLUSTRATED PARTS LIST

For Solenoid and Control Board Assemblies and Mounting

This list contains replaceable parts used in your generator. When ordering parts, follow the instructions listed under *Replacement Parts* on page 32 of this manual.

KEY NO.	PART NUMBER	DESCRIPTION	QTY.
1	100105-01	Control Board Assembly	1
2	26499000	Hex Head Screw, 10-32 x 3/4"	4
3	100321-01	Nylon Spacer	4
4	WP-C3	Flat Washer, #10	4
5	26514000	Lock Nut, 10-32	4
6	100324-03	Solenoid Assembly (Includes Plunger, Nut, and Lock Washer)	1
7	100755-02	Linkage Rod	1
	118632-01	Linkage Rod (MGH6500AIE Only)	1
8	22822000	Roll Pin	1
9	118635-01	Solenoid Mounting Bracket	1
10	100328-01	Bolt, M8 x 25mm	1
11	108585-01	Flat Washer, M8	1
12	100329-01	Lock Nut, M8	1
PARTS AVAILABLE NOT SHOWN			
	100320-01	Yellow Wire	1
	100322-01	White Wire (with 2 Flags)	1
	100322-02	White Wire (with 1 Flag and 1 Spade)	1
	100366-01	Rocker Switch	1
	100334-01	Auto-Idle Decal	1

MASTER

PORTABLE GASOLINE GENERATORS

ILLUSTRATED PARTS LIST

For Models MGH4000D, MGH4000DI, MGH5000E, MGH5000EI, MGH5000EIE, and MGH6500AIE Control Panel

This list contains replaceable parts used in your generator. When ordering parts, follow the instructions listed under *Replacement Parts* on page 32 of this manual.

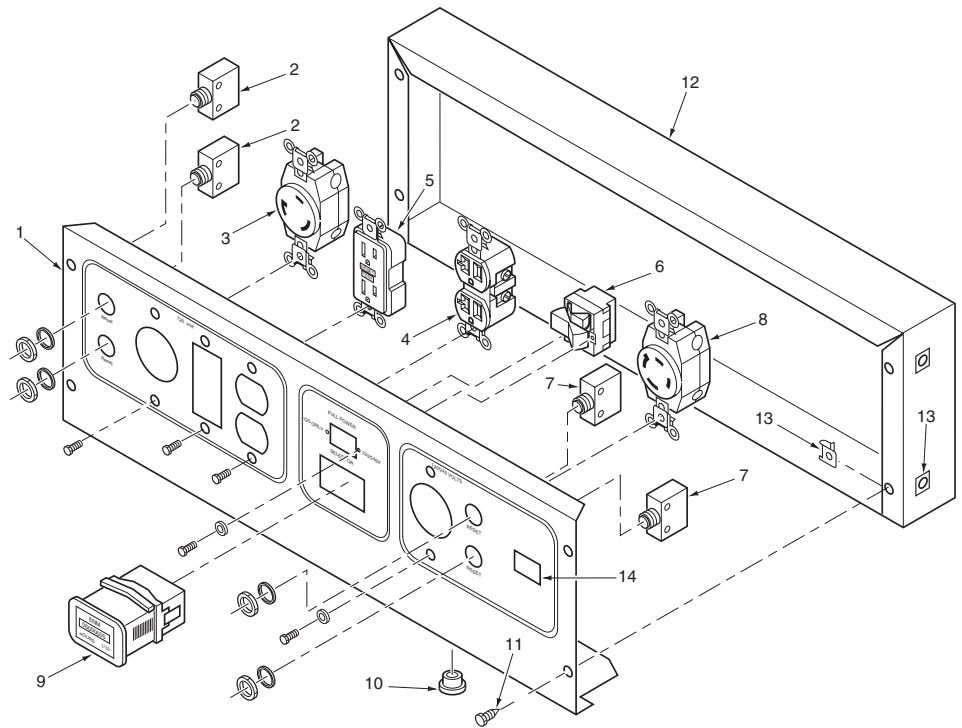

KEY NO.	PART NUMBER FOR MODEL			DESCRIPTION	QTY.
	MGH4000D MGH4000DI	MGH5000E MGH5000EI MGH5000EIE	MGH6500AIE		
1	103349-01	103349-02	103349-05	Control Panel	1
2	22616009	22616009	22616009	Circuit Breaker, 20 Amp *	2
3	099833-01	099833-01	099833-01	120V, 30A Twist-Lock Receptacle *	1
4	104202-01	104202-01	104202-01	120V, 20A Duplex Receptacle *	1
5	100445-01	100445-01	100445-01	120V, 15A Duplex (GFCI) Receptacle *	1
6	099956-01	099956-01	—	Full Power Selector Switch *	1
7	22616009	—	—	Circuit Breaker, 20 Amp *	2
	—	22616011	—	Circuit Breaker, 25 Amp *	2
	—	—	22616010	Circuit Breaker, 30 Amp *	2
8	099834-01	099834-01	—	120/240V, 20A Twist-Lock Receptacle *	1
	—	—	099835-01	120/240V, 30A Twist-Lock Receptacle *	1
9	101350-01	101350-01	101350-01	Hour Meter	1
10	099760-01	099760-01	099760-01	Bushing	1
11	100410-01	100410-01	100410-01	Sems Screw, #8-18 x 1/2"	4
12	100149-01	100149-01	100149-01	Control Box	1
13	22261000	22261000	22261000	U-Nut	8
14	099997-01	099997-01	099997-01	Switch Plug	1
†	118681-01	118681-02	—	Control Panel Assembly	1
†	118681-03	118681-04	118681-05	Control Panel Assembly - Auto Idle Models	1
Δ	100177-07	100177-07	100177-07	Panel Schematic Decal	1

* Includes fastening hardware

Δ Not shown

† Includes reference numbers 1 through 13

OWNER'S MANUAL

REPLACEMENT PARTS AND ACCESSORIES

For original replacement parts and accessories, contact your nearest Authorized Dealer or Authorized Service Center for this product. If they can not supply the part or accessory, contact your nearest Parts Central listed below. Each Authorized Dealer, Authorized Service Center, and Parts Central is independently owned and operated.

See pages 19 through 31 for an Illustrated Parts List.

If you need additional referral information, contact our Technical Service Department (see *Technical Service*, page 15).

In Canada call 1-800-561-3372 for parts information.

Heavy-Duty Wheel Kit – PA2022 For Models MGH4000D, MGH4000DI, MGH5000E, MGH5000EI, MGH5000EIE, and MGH6500AIE

Wheelbarrow-style wheel kit. Makes generator easy for one person to move.

This kit includes:

- Large 12-inch wheels for easy rolling
- Powder coated tubing and plated hardware for long life
- Long handles with thick grips for greater comfort and control

Complete installation instructions included.

Automatic Idle Kit – PA2011 For Models MGH4000D and MGH5000E

Automatically reduces engine speed when no power is being used. Reduces fuel consumption and engine noise. Increases engine life.

Complete installation and operation instructions included.

REPAIR SERVICE

Note: Only use original replacement parts. This will protect your warranty coverage for parts replaced under warranty.

Each Authorized Service Center is independently owned and operated.

For additional Service Center or warranty information, call 1-800-858-8501 or visit our Technical Service web site at www.desatech.com.

WARRANTY SERVICE

If product requires warranty service, return it to nearest Authorized Service Center. You must show proof of purchase. If faulty materials or workmanship caused damage, we will repair or replace product without charge. *Note:* Normal wear, misuse, abuse, neglect, or accidental damage is not covered under warranty.

NON-WARRANTY SERVICE

If product requires service, return it to nearest Authorized Service Center. Repairs will be billed to you at regular repair list prices.

PARTS CENTRALS

These Parts Centrals are privately owned businesses. They have agreed to support our customer's needs by providing original replacement parts and accessories.

Tool & Equipment

5 Manila Drive
Hamden, CT 06514-0322
203-248-7553
1-800-397-7553

Grainger Parts Operations

1657 Shermer Road
Northbrook, IL 60062-5362
708-498-5900
1-800-323-0620
www.grainger.com

Portable Heater Parts

342 North County Road 400 East
Valparaiso, IN 46383-9704
219-462-7441
1-800-362-6951
www.portableheaterparts.com
sales@portableheaterparts.com
techservice@portableheaterparts.com

FBD

1349 Adams Street
Bowling Green, KY 42103-3414
270-846-1199
1-800-654-8534
franktalk@aol.com

Master Part Distributors

1251 Mound Avenue NW
Grand Rapids, MI 49504-2672
616-791-0505
1-800-446-1446
www.masterparts.net

Bowden Electric Motor Service

1681 S. Wesleyan Blvd.
Rocky Mount, NC 27803
252-446-4203

East Coast Energy

10 East Route 36
West Long Branch, NJ 07764-1501
1-800-755-8809

Laportes

2444 N 5th Street
Hartsville, SC 29550-7704
843-332-0191

MTA Distributors

555 Hickory Hills Blvd.
Nashville, TN 37189-9244
615-299-8777
1-800-264-0225

Industrial Hardware

4109 Bainbridge Blvd.
Chesapeake, VA 23324-1403
804-543-2232
1-800-788-0008
catatam@erols.com

Mills Lawn and Garden

928 Commonwealth Place
Virginia Beach, VA 23464
757-361-9293
www.mills-parts.com

Tuco Industrial Products

5223 180th Street SW
Suite 4A-1
Lynnwood, WA 98037-4506
425-743-9533
1-800-735-1268
www.tucoheat.com

WARRANTY INFORMATION

KEEP THIS WARRANTY

Model _____
Serial No. _____
Date Purchased _____

Always specify model and serial numbers when communicating with the factory.

We reserve the right to amend these specifications at any time without notice. The only warranty applicable is our standard written warranty. We make no other warranty, expressed or implied.

FIVE-YEAR LIMITED WARRANTY GASOLINE PORTABLE GENERATORS

DESA Specialty Products™ makes no warranty with respect to the engine and engine components not of its manufacture. They are subject to warranties of their manufacturers. Honda warrants the engine. See engine owner's manual for engine warranty information.

DESA Specialty Products™ warrants each generator, excluding engine, of its manufacture, to be free from defects in material and workmanship for five years from the date of first purchase from an authorized dealer, provided that the product has been properly installed, maintained, and operated in accordance with all applicable instructions. The bill of sale or proof of purchase must be presented at the time a claim is made under this warranty.

This warranty is extended only to the original retail purchaser. This warranty covers only the parts and labor required to restore this unit to its proper operating condition. Warranty parts must be obtained through factory authorized dealers and service centers for this product. These dealers and service centers will provide original factory replacement parts. Failure to use original factory replacement parts voids this warranty.

This warranty does not apply to parts that are not in original condition because of normal wear and tear, or parts that fail or become damaged as a result of misuse, abuse, negligence, accident, lack of proper maintenance, alteration, modification, tampering, contaminated fuels, repair using improper parts, or repair by anyone other than an authorized dealer or service center. Routine maintenance is the responsibility of the owner. Travel, handling, transportation, and incidental costs associated with warranty repairs are not reimbursable under this warranty and are the responsibility of the owner.

To the full extent allowed by the law of the jurisdiction that governs the sale of the product, this express warranty excludes any and all other expressed warranties and limits the duration of any and all implied warranties, including warranties of merchantability and fitness for a particular purpose to five years from the date of first purchase, and DESA Specialty Products'™ liability is hereby limited to the purchase price of the product and DESA Specialty Products™ shall not be liable for any other damages whatsoever including indirect, incidental, or consequential damages.

Some states do not allow limitation of how long an implied warranty lasts or an exclusion or limitation of incidental or consequential damages, so the above limitation of damages may not apply to you.

This warranty provides the original purchaser with specific rights. For information regarding those rights, please consult the applicable state laws.



Bowling Green, KY 42102-9004

www.desatech.com

118683-01
REV. A
03/06